

6 T SCM-MAGNETOMETER HTS ELECTROMAGNET

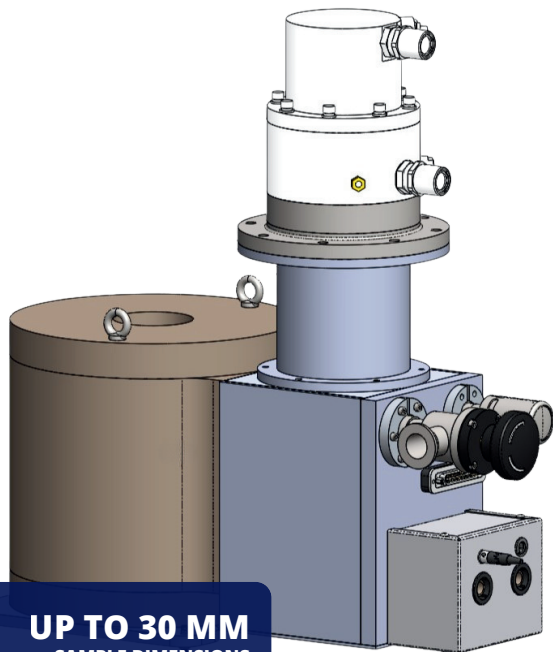

MODEL: 2G-SCM 6T

ACCEPTING EXPRESSIONS OF INTEREST



A quick and accurate automatic measurement of magnetization characteristics for high coercivity magnets using a 6 T high-Tc superconducting magnet.

- **Superconducting solenoid eliminates pole saturation** enabling measurement of high coercivity materials
- **A superconducting magnet enables a continuous high static magnetic field**, facilitating measurement of large permanent magnet samples while minimising eddy current effects.
- **No influence of magnetic aftereffects found in pulsed magnetic fields**, enabling accurate measurement of processing conditions, etc.
- **Equipped with a heater for varying sample temperature**, enabling measurement of magnet properties at high temperatures

This design is fully cryogen-free, allowing fast sweep rates with minimal overhead; it produces a low fringe field for sensitive settings yet still accommodates large samples and can be held at any field strength with minimal influence of eddy currents. In addition, the helium compressor can be installed three to ten metres from the magnet, simplifying room layout and reducing noise near the sample area.

UP TO 30 MM
SAMPLE DIMENSIONS

~ 8 MINUTE
MEASUREMENT TIME

EDDY CURRENT
INFLUENCE MINIMISATION

CRYOGEN-FREE
NO LIQUID HELIUM

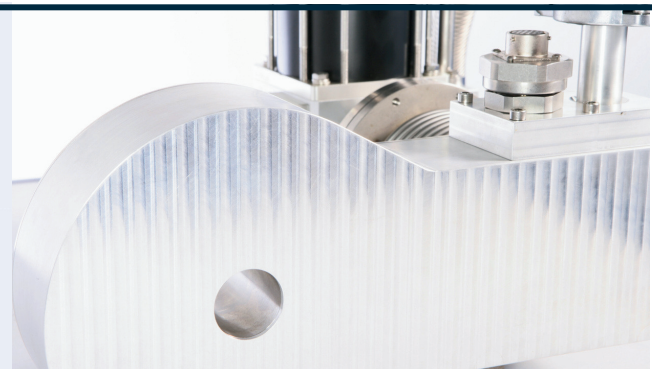
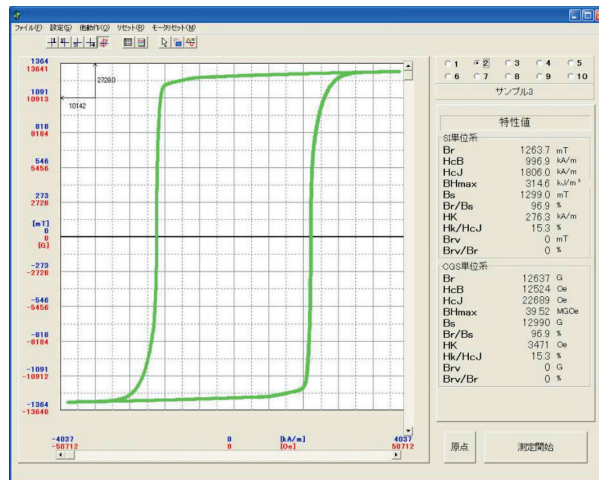

HTS-110's global client base includes tier-one data storage companies; manufacturers; universities; and national research institutes including ALBA, ANL, ANSTO, BNL, CAS, FZJ, HZB, ILL, IMRE, JAXA, LNLS, MSL (NZ), NIST, NUS (SSLS), PAL, RAL, RTRI, TATA, TPS, and TUM (FRMII).

info@hts-110.com
+64 4 570 8880
HTS-110.com

6 T SCM-MAGNETOMETER HTS ELECTROMAGNET



ACCEPTING EXPRESSIONS OF INTEREST

MAGNETOMETER SPECIFICATIONS

Sample	Sample dimensions	Up to □ 30 mm
Measuring equipment and software	Measurement accuracy	Within ±1[%] of calibration standards (Br, HcJ)
	Measurement Time	Approx. 8 min
	Main measurement items	Residual Magnetic Flux Density (Br)
		Coercivity (Hcb/HcJ)
Max. Energy (BHMax)		
	Degree of Orientation (Br/Bs)	
Elevating device (heater)	Temperature range	RT~200 °C
Superconducting Magnet	Central magnetic field	6 T
	Bore diameter	φ70 mm
	Excitation speed	5 s/T

Measurement with HTS BH curve tracer

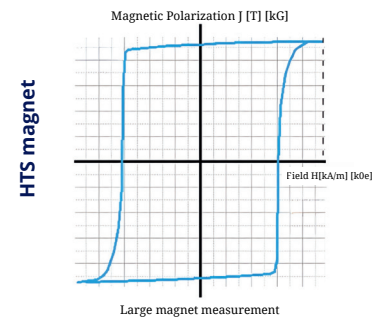

Limitations with other systems:

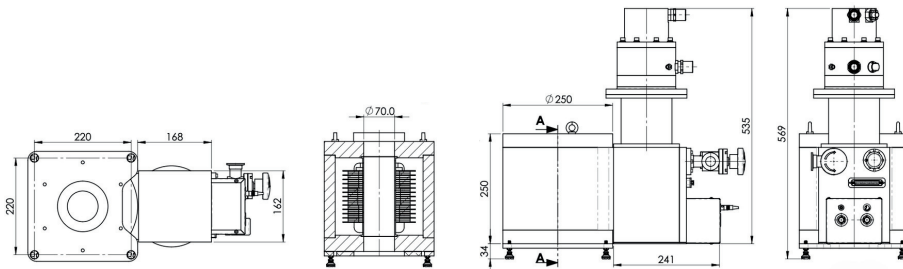
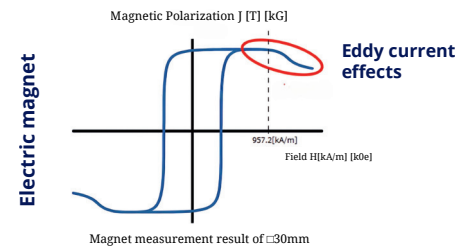
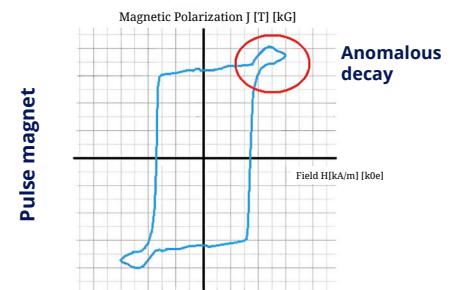

HTS MAGNET SPECIFICATIONS

Maximum Field	6 T (10 T option available)
Fast Sweep Rate	5 s/T
Bore Size	Φ70 mm
Field Homogeneity	Volume 1: better than ±0.2% within D= 10 mm, L= 10 mm
	Volume 2: better than ±5% within D= 70 mm, L= 50 mm
Fringe Field (5 Gauss)	1.2 m in the magnet axial direction
	1.0 m in the magnet radial direction
Sample Capability	Up to 30 mm square
Max Operating Current	150 A
Dimensions	550 x 250 x 570 mm (L x W x H) incl. cryocooler and manifold. Separate helium compressor can be sited 3-10 m away
Weight	Magnet: 60 kg. Compressor: 96 kg.
Facility Input	Air and water-cooled compressors, 4.6-6.4 kW input



HTS-110.COM
+64 4 570 8880
info@hts-110.com

